



Laboratory Equipment Manufacturer  
www.mrclab.com



***SD card real time data-logger.  
Plus Type K /Type J thermocouple ports.***

# UVC LIGHT METER

Model : UVC-254SD



Please read the following instructions carefully and always keep this manual within easy reach.

## OPERATION MANUAL

**NOTE: if you are unable to turn off the meter &/or change settings.** This often occurs when the meter is in record mode (REC). This is a fail-safe to prevent someone from inadvertently turning off the meter during the data logging process. In order to determine if this mode had been activated, you should see the (REC) indication at the top of the reading on the screen of the meter. Therefore preventing the meter from being powered off.

If this is the case, and you are not in the middle of data-logging, hold the (REC) button for 2 to 3 seconds or until the (REC) indicator is off. At this time you will then be able to power the meter off as you normally would by holding the (POWER) button for 2 to 3 seconds until the meter is powered off.

# TABLE OF CONTENTS

1. FEATURES.....	1
2. SPECIFICATIONS.....	2
3. FRONT PANEL DESCRIPTION.....	6
3-1 Display.....	6
3-2 Power Button ( ESC, Backlight Button ).....	6
3-3 Hold Button ( Function, Next Button ).....	6
3-4 REC Button ( Enter Button ).....	6
3-5 SET Button ( ▼ Button, Time check Button ).....	6
3-6 Logger Button ( ▲ Button, Sampling time check Button ).....	6
3-7 Probe input socket.....	6
3-8 Type K/J Probe Input Socket.....	6
3-9 SD card socket.....	6
3-10 RS-232 Output Terminal.....	6
3-11 Reset Button.....	6
3-12 DC 9V Power Adapter Input Socket.....	6
3-13 Battery Compartment/Cover.....	6
3-14 Battery Cover's Screws.....	6
3-15 Stand.....	6
3-16 Tripod Fix Nut.....	6
3-17 UVC Probe Plug.....	6
3-18 UVC Sensor body.....	6
3-19 UVC Sensor.....	6
4. MEASURING PROCEDURE.....	7
4-1 Function selection/Measurement.....	7
4-2 Data Hold.....	9
4-3 Data Record ( Max./ Min. reading ).....	10
4-4 LCD Backlight ON/OFF.....	10
5. DATALOGGER.....	11
5-1 Preparation before execute datalogger function.....	11
5-2 Auto Datalogger ( Set sampling time $\geq$ 1 second ).....	12
5-3 Manual Datalogger ( Set sampling time = 0 second ).....	13
5-4 Check time information.....	13
5-5 Check sampling time information.....	14
5-6 SD Card Data structure.....	14
6. Saving data from the SD card to the computer.....	15
7. ADVANCED SETTING.....	16
7-1 Set clock time ( Year/Month/Date, Hour/Minute/ Second ).....	17
7-2 Decimal point of SD card setting.....	18
7-3 Auto power OFF management.....	18
7-4 Set beep Sound ON/OFF.....	19
7-5 Select the thermometer type to Type K or Type J.....	19
7-6 Select the temperature unit to °C or °F.....	20
7-7 Set sampling time.....	20
7-8 SD memory card format.....	20
8. POWER SUPPLY from DC ADAPTER.....	21
9. BATTERY REPLACEMENT.....	21
10. SYSTEM RESET.....	22
11. RS232 PC serial interface.....	22
12. Optional Type K Temp. probe.....	24
13. PATENT.....	25

# 1. FEATURES

- \* Short wave 254 nm ultra-violet irradiance measurement. Professional UVC light meter, used to measure the UVC irradiation value under the UVC light source. source.
- \* Two ranges : **2 mW/cm<sup>2</sup>, 20 mW/cm<sup>2</sup>.**
- \* UVC Light sensor with cosine correction filter.
- \* UVC function built-in Zero button.
- \* Measures UVC output to verify efficacy of germicidal lamps, especially for the medical field.
- \* Microprocessor circuit provides high reliability and durability.
- \* Separate UVC LIGHT probe allows user to measure the UVC light at an optimum position and angle for the lamp.
- \* Type K, Type J thermocouple port.
- \* Built-in Time/Date Stamp and real time data recorder (sampling time can be set at intervals of 1 second to 3600 seconds) and stored on optional SD memory card.
- \* Manual datalogger is available ( set the sampling time to 0 ).
- \* When using an optional SD memory card. User can Record ( year/month/date/ hour/minute/second ) and reading directly to a spreadsheet.
- \* Tripod mount built-in to instrument case.
- \* Optional RS-232 Cable and recording software available for external datalogging.
- \* Powered by batteries or optional power supplies.

- \* SD card capacity : 1 GB to 16 GB.
- \* LCD with green back-light for easy reading.
- \* Auto power off (can be disabled).
- \* Data hold, record max. and min. readings.
- \* Microcomputer circuit offers high accuracy.
- \* Power by (6) AA (1.5 V) alkaline batteries or optional DC 9V adapter.
- \* RS232/USB PC computer interface.

## 2. SPECIFICATIONS

### *2-1 General Specifications*

Circuit	Custom microprocessor LSI circuit.
Display	LCD size : 52 mm x 38 mm LCD with green backlight ( ON/OFF ).
Measurement	UVC Light Type K/J thermometer
UVC Sensor spectrum cover range	220nm to 280nm. (254nm optimum). <i>* UVC light sensor spectrum, refer to page 5.</i>
UVC sensor structure	exclusive UV photo sensor with the cosine correction filter.
UV light zero adjustment	Push button.
Memory with Recall	Records Maximum & Minimum reading with recall.

Datalogger Sampling Time Setting range	Auto	1 second to 3600 seconds <i>@ Sampling time can set to 1 second, but memory data may loss.</i>
	Manual	Push the data logger button once will save data one time. <i>@ Set the sampling time to 0 second.</i> <i>@ Manual mode, can also select the 1 to 99 position ( Location ) no.</i>
Memory Card	SD memory card. 1 GB to 16 GB.	
Advanced setting	<ul style="list-style-type: none"> <li>* Set clock time ( Year/Month/Date, Hour/Minute/ Second )</li> <li>* Decimal point of SD card setting</li> <li>* Auto power OFF management</li> <li>* Set beep Sound ON/OFF</li> <li>* Set thermometer type to Type K or Type J</li> <li>* Set temperature unit to °C or °F</li> <li>* Set sampling time</li> <li>* SD memory card Format</li> </ul>	
Temperature Compensation	Automatic temperature compensation for the type K/J thermometer port.	
Data Hold	Freezes the current display reading.	
Memory Recall	Maximum & Minimum value.	
Sampling Time of Display	Approximately 1 second.	
Data Output	RS 232/USB PC computer interface. <ul style="list-style-type: none"> <li>* <i>Connect the optional RS232 cable UPCB-02 will get the RS232 plug.</i></li> <li>* <i>Connect the optional USB cable USB-01 will get the USB plug.</i></li> </ul>	
Operating Temperature	32° F to 122° F (0 to 50 °C).	
Operating Humidity	Less than 85% R.H.	

Power Supply	* Alkaline or heavy duty DC 1.5 V battery ( UM3, AA ) x 6 PCs, or equivalent.	
	* DC 9V adapter input. ( AC/DC power adapter is optional ).	
Power Current	Normal operation ( w/o SD card saving data and LCD Backlight is OFF) : <i>Approx. DC 6.5 mA.</i>	
	With SD card saving data and LCD Backlight OFF) : <i>Approx. DC 30 mA.</i>	
	* <i>If LCD backlight on, the power consumption will increase approx. 16 mA.</i>	
Weight	Meter	351 g
	UVC probe	103 g
Dimension	Meter	177 x 68 x 45 mm
	UVC probe	38 mm DIA. x 25 mm
Accessories Included	* Instruction manual..... 1 PC * UVC light sensor..... 1 PC * Hard carrying case, CA-06..... 1 PC	
Optional Accessories	SD Card ( 2 GB ) Type K thermocouple probe. AC to DC 9V adapter. USB cable, USB-01. RS232 cable, UPCB-02. Data Acquisition software, SW-U801-WIN.	

## ***2-2 Electrical Specifications (23± 5 °C)***

### **UVC Light range/resolution/accuracy**

Measurement ranges & resolution	Range 1 : 2 mW/cm <sup>2</sup> : 1.999 mW/cm <sup>2</sup> x 0.001 mW/cm <sup>2</sup> Range 2 : 20 mW/cm <sup>2</sup> :
Accuracy	± ( 4 % FS + 2 dgt ).      FS : full scale * <i>UVC Calibration is executed under the UVC light &amp; and compare with the standard UVC light meter.</i>

### UVC Light sensor spectrum

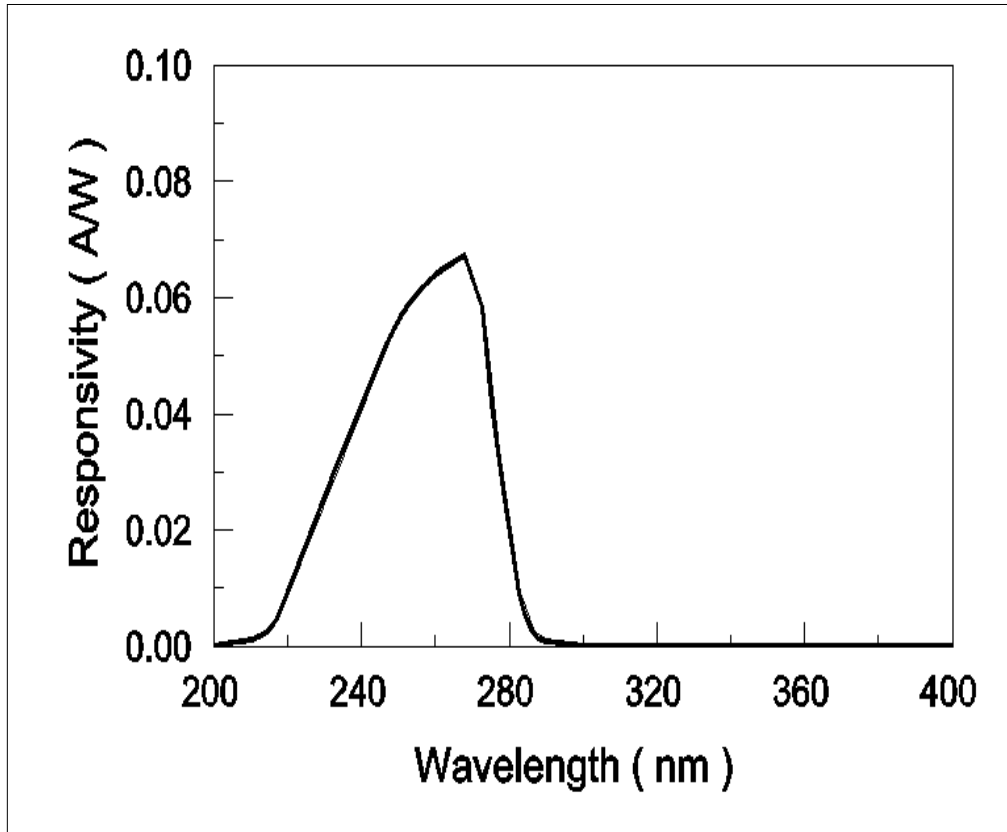

### Type K/J thermometer

Sensor Type	Resolution	Range	Accuracy
Type K	0.1 °C	-50.0 to 1300.0 °C -50.1 to -100.0 °C	± ( 0.2 % + 0.5 °C ) ± ( 0.2 % + 1 °C )
	0.1 °F	-58.0 to 2372.0 °F -58.1 to -148.0 °F	± ( 0.2 % + 1 °F ) ± ( 0.2 % + 1.8 °F )
Type J	0.1 °C	-50.0 to 1100.0 °C -50.1 to -100.0 °C	± ( 0.2 % + 0.5 °C ) ± ( 0.2 % + 1 °C )
	0.1 °F	-58.0 to 2012.0 °F -58.1 to -148.0 °F	± ( 0.2 % + 1 °F ) ± ( 0.2 % + 1.8 °F )

*@ Above specification tests under the environment RF Field Strength less than 3 V/M & frequency less than 30 MHz only.*

## 3. FRONT PANEL DESCRIPTION

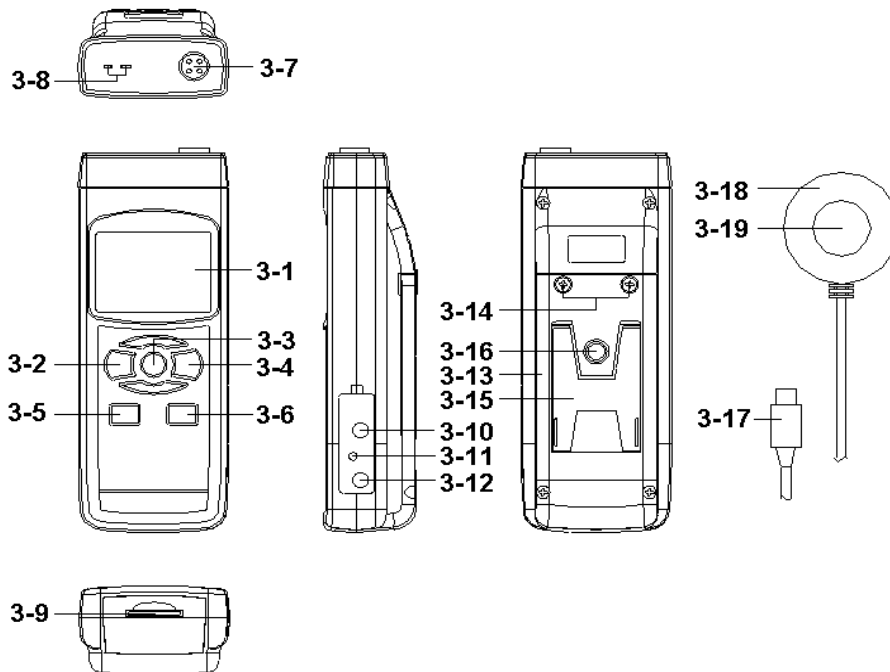

Fig. 1

- 3-1 Display
- 3-2 Power Button ( ESC, Backlight Button )
- 3-3 Hold Button ( Function, Next Button )
- 3-4 REC Button ( Enter Button )
- 3-5 SET Button ( ▼ Button, Time check Button )
- 3-6 Logger Button ( ▲ Button, Sampling time check Button, Zero Button )
- 3-7 Probe input socket
- 3-8 Type K/J Temp. Probe Input Socket
- 3-9 SD card socket
- 3-10 RS-232 Output Terminal
- 3-11 Reset Button
- 3-12 DC 9V Power Adapter Input Socket
- 3-13 Battery Compartment/Cover
- 3-14 Battery Cover Screws
- 3-15 Stand
- 3-16 Tripod Fix Nut
- 3-17 UVC Probe Plug
- 3-18 UVC Sensor body
- 3-19 UVC Sensor



## 4. MEASURING PROCEDURE

### ***4-1 Function selection/Measurement***

1) Turn on the meter by pressing the " Power Button " ( 3-2, Fig. 1 ) momentarily.

*\* Pressing the " Power Button " ( 3-2, Fig. 1 ) continuously and > 2 seconds again will turn off the meter.*

2) The meter can select 2 kind function as :

**a. UVC Light meter**

**b. Type K/J Thermometer**

Pressing the " Function Button " ( 3-3, Fig. 1 ) continuously ( not release the button ), the Display will show the following text in sequence :

<b>C</b>	<b>UVC Light meter</b>
<b>tP</b>	<b>Type K/J Thermometer</b>

Until the Display show the desired mode ( Function ), just release the " Function Button " ( 3-3, Fig. 1 ), the meter will execute this function with default.

## **UVC Light measurement**

- a. Set the function to the UVC light meter, refer to page 7.
- b. Install the " UVC Probe Plug " ( 3-17, Fig. 1 ) into the " Probe Input Socket " ( 3-7, Fig. 1 ).
- c. Power on the meter by pressing the " Power Button " ( 3-2, Fig. 1 ). The display will show the " mW/cm<sup>2</sup> " unit. Now the meter is ready for making the UVC light measurement.
- d. Use the fingers to hold the " UVC Sensor body " ( 3-18 ), face the " UVC Sensor " ( 3-19, Fig. 1 ) against to the measurement UVC light source directly. The display will show the UVC light measurement value.

### ***Zero adjustment :***

***During the UVC measurement, if blank the UVC Sensor ( 3-19, Fig. 1 ) , the Display not show zero value, press the " Zero Button, Logger Button " ( 3-6, Fig. 1 ) > 3 seconds, Display will show zero value.***

## **Type K/J thermometer**

- a. Function select to " Type K/J thermometer "
- b. Not install the " Probe Plug " ( 3-17, Fig. 1 ) into the " Probe Input Socket " ( 3-7, Fig. 1 ).
- c. Plug the Thermocouple Temp. Probe ( Type K Temp. probe or Type J Temp. probe, optional ) into " Type K/J Probe Input Socket " ( 3-8, Fig. 1 )  
The Display will show the measuring value that sensing from the Temp. probe.
- d. If the Display show the indicator " K ", it is ready for Type K thermometer.  
If the Display show the indicator " J ", it is ready for Type J thermometer.

*Remark :*

*The meter is defaulted to " Type K thermometer ".  
If intend to select the " Type J thermometer with default , please refer chapter 7-5 ( page 19 ).*

### **4-2 Data Hold**

During the measurement, press the " Hold Button " ( 3-3, Fig. 1 ) once will hold the measured value & the LCD will display a " HOLD " symbol.  
Press the " Hold Button " once again will release the data hold function.

### **4-3 Data Record ( Max., Min. reading )**

- 1) The data record function records the maximum and minimum readings. Press the " REC Button " ( 3-4, Fig. 1 ) once to start the Data Record function and there will be a " REC. " symbol on the display.
- 2) With the " REC. " symbol on the display :
  - a) Press the " REC Button " ( 3-4, Fig. 1 ) once, the " REC. MAX. " symbol along with the maximum value will appear on the display.  
If intend to delete the maximum value, just press the " Hold Button " ( 3-3, Fig. 1 ) once, then the display will show the " REC. " symbol only & execute the memory function continuously.
  - b) Press the " REC Button " ( 3-4, Fig. 1 ) again, the " REC. MIN. " symbol along with the minimum value will appear on the display.  
If intend to delete the minimum value, just press the " Hold Button " ( 3-3, Fig. 1 ) once, then the display will show the " REC. " symbol only & execute the memory function continuously.
  - c) To exit the memory record function, just press the " REC " button for 2 seconds at least. The display will revert to the current reading.

### **4-4 LCD Backlight ON/OFF**

After power ON, the " LCD Backlight " will light automatically. During the measurement, press the " Backlight Button " ( 3-2, Fig. 1 ) once will turn OFF the " LCD Backlight ".

Press the " Backlight Button " once again will turn ON the " LCD Backlight " again.

## 5. DATALOGGER

### *5-1 Preparation before execute datalogger function*

a. Insert the SD card

Prepare a " SD memory card " ( 1 G to 16 G, optional ), insert the SD card into the " SD card socket " ( 3-9, Fig. 1). The front panel of the SD card should face against the the down case.

***\* It recommend use memory card  $\leq$  4 GB.***

b. SD card Format

If SD card just the first time use into the meter, it recommend to make the " SD card Format " at first. , please refer chapter 7-8 ( page 20 ).

***\* It recommend strongly, do not use memory cards that have been formatted by other meter or by other installation ( such as camera... ). Reformat the memory card with your meter.***

c. Time setting

If the meter is used at first time, it should to adjust the clock time exactly, please refer chapter 7-1 ( page 17 ).

d. Decimal format setting



The numerical data structure of SD card is default used the " . " as the decimal, for example "20.6" "1000.53" . But in certain countries ( Europe ...) is used the " , " as the decimal point, for example " 20, 6 " "1000,53". Under such situation, it should change the Decimal character at first, details of setting the Decimal point, refer to Chapter 7-2, page 18.

## **5-2 Auto Datalogger ( Set sampling time $\geq 1$ second )**

### **a. Start the datalogger**

Press the " REC Button ( 3-4, Fig. 1 ) once , the LCD will show the text " REC ", then press the " Logger Button " ( 3-6, Fig. 1 ), the " REC " will flashing, at the same time the measuring data along the time information will be saved into the memory circuit.

*Remark :*

*\* How to set the sampling time, refer to Chapter 7-7, page 20.*

*\* How to set the beeper sound is enable, refer to Chapter 7-4, page 19.*

### **b. Pause the datalogger**

During execute the Datalogger function , if press the " Logger Button " ( 3-6, Fig. 1 ) once will pause the Datalogger function ( stop to save the measuring data into the memory circuit temporally ). In the same time the text of " REC " will stop flashing.

*Remark :*

*If press the " Logger Button " ( 3-6, Fig. 1 ) once again will execute the Datalogger again, the text of " REC " will flashing .*

### **c. Finish the Datalogger**

During pause the Datalogger, press the " REC Button " ( 3-4, Fig. 1) continuously at least two seconds, the " REC " indication will be disappeared and finish the Datalogger.

### **5-3 Manual Datalogger ( Set sampling time = 0 second )**

#### **a. Set sampling time is to 0 second**

Press the " REC Button ( 3-4, Fig. 1 ) once , the LCD will show the text " REC ", then press the " Logger Button " ( 3-6, Fig. 1 ) once, the " REC " will flashing once and Beeper will sound once, at the same time the measuring data along the time information will be saved into the memory circuit. The lower Display will show the Position ( Location ) no. and saved into the SD card too.

*Remark :*

*During execute the Manual Datalogger, press the " ▼ Button " ( 3-5, Fig, 1 ) the lower no. ( position no. ) will flashing. It can use the " ▲ Button " ( 3-6, Fig. 1 ) or " ▼ Button " ( 3-5, Fig. 1 ) to set the measuring position ( 1 to 99, for example room 1 to room 99 ) to identify the measurement location , the lower Display will show P x ( x = 1 to 99 ). After the position no. is selected, t press the " Enter Button " ( 3-4, Fig. 1 ) to confirm.*

#### **b. Finish the Datalogger**

Press the " REC Button " ( 3-4, Fig. 1) continuously at least two seconds, the " REC " indication will be disappeared and finish the Datalogger.

### **5-4 Check time information**

During the normal measurement ( not execute the Datalogger ), If press " Time check Button " ( 3-5, Fig. 1 ) once , the lower LCD display will present the time information of Year, Month/Date, Hour/Minute

### **5-5 Check sampling time information**

During the normal measurement ( not execute the Datalogger ), If press " Sampling Button " ( 3-6, Fig. 1 ) once , the lower LCD display will present the Sampling time information in second unit.

### **5-6 SD Card Data structure**

1) When the first time, the SD card is used into the meter, the SD card will generate a folder :

#### ***UVC01***

2) If the first time to execute the Datalogger, under the route UVC01\, will generate a new file name UVC01001.XLS.  
After exist the Datalogger, then execute again, the data will save to the UVC01001.XLS until Data column reach to 30,000 columns, then will generate a new file, for example UVC01002.XLS

3) Under the folder UVC01\, if the total files more than 99 files, will generate anew route, such as UVC02\ .....

4) The file's route structure :

```
UVC01\  UVC01001.XLS
        UVC01002.XLS
        .....
        UVC01099.XLS
UVC02\  UVC02001.XLS
        UVC02002.XLS
        .....
        UVC02099.XLS
UVCXX\  .....
```

*Remark :*

*XX : Max. value is 10.*



## 6. Saving data from the SD card to the computer ( EXCEL software )

- 1) After execute the Data Logger function, take away the SD card out from the " SD card socket " ( 3-9, Fig. 1 ).
- 2) Plug in the SD card into the Computer's SD card slot ( if your computer build in this installation ) or insert the SD card into the " SD card adapter ". then connect the " SD card adapter " into the computer.
- 3) Power ON the computer and run the " EXCEL software ". Down load the saving data file ( for example the file name : UVC01001.XLS, UVC01002.XLS ) from the SD card to the computer. The saving data will present into the EXCEL software screen ( for example as following EXCEL data screens ) , then user can use those EXCEL data to make the further Data or Graphic analysis usefully.

EXCEL data screen ( for example )

	A	B	C	D	E	F
1	Place	Date	Time	Value	Unit	
2	1	2009/12/11	09:55:56	2.37	UVC mW/cm2	
3	2	2009/12/11	09:55:58	2.4	UVC mW/cm2	
4	3	2009/12/11	09:56:00	2.38	UVC mW/cm2	
5	4	2009/12/11	09:56:02	3.29	UVC mW/cm2	
6	5	2009/12/11	09:56:04	3.74	UVC mW/cm2	
7	6	2009/12/11	09:56:06	3.89	UVC mW/cm2	
8	7	2009/12/11	09:56:08	3.14	UVC mW/cm2	
9	8	2009/12/11	09:56:10	2.23	UVC mW/cm2	
10	9	2009/12/11	09:56:12	0.953	UVC mW/cm2	
11	10	2009/12/11	09:56:14	1.011	UVC mW/cm2	
12	11	2009/12/11	09:56:16	0.981	UVC mW/cm2	
13	12	2009/12/11	09:56:18	0.673	UVC mW/cm2	
14	13	2009/12/11	09:56:20	0.892	UVC mW/cm2	
15	14	2009/12/11	09:56:22	2.16	UVC mW/cm2	
16	15	2009/12/11	09:56:24	3.55	UVC mW/cm2	
17	16	2009/12/11	09:56:26	3.97	UVC mW/cm2	
18	17	2009/12/11	09:56:28	3.94	UVC mW/cm2	
19	18	2009/12/11	09:56:30	3.94	UVC mW/cm2	
20	19	2009/12/11	09:56:32	3.94	UVC mW/cm2	
21	20	2009/12/11	09:56:34	3.95	UVC mW/cm2	

EXCEL graphic screen ( for example )

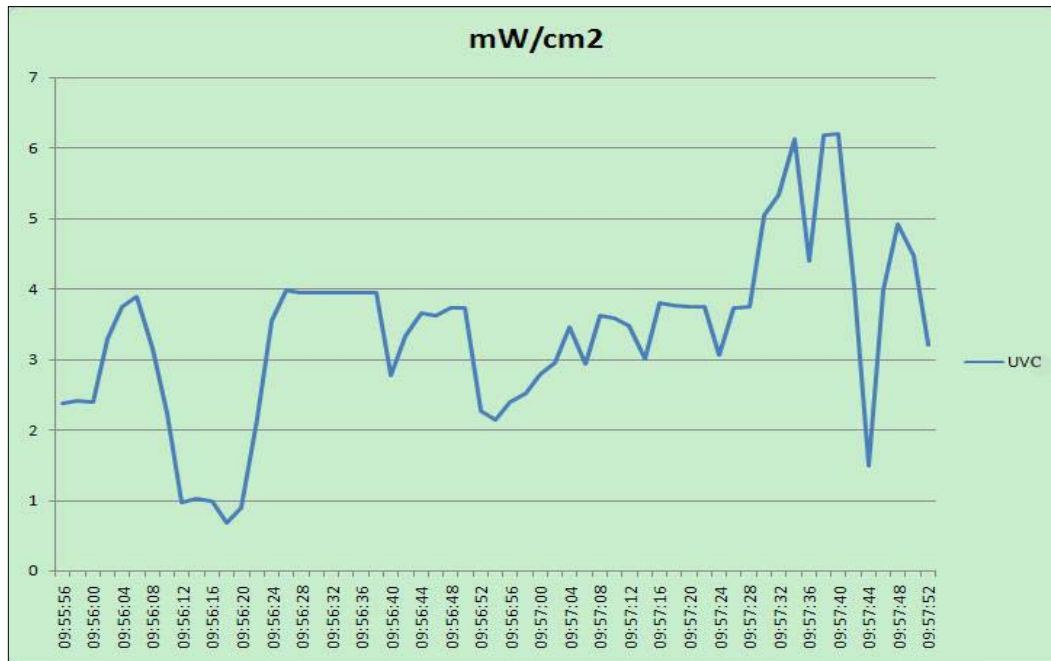

## 7. ADVANCED SETTING

Under do not execute the Datalogger function, press the " SET Button " ( 3-5, Fig. 1 ) continuously at least two seconds will enter the " Advanced Setting " mode. then press the " Next Button " (3-3, Fig. 1 ) once a while in sequence to select the eight main function, the lower display will show :

- dAtE**.....Set clock time ( Year/Month/Date, Hour/Minute/Second )
- dEC**.....Set SD card Decimal character
- PoFF**.....Auto power OFF management
- bEEP**.....Set beeper sound ON/OFF
- tYPE**..... Select the Thermometer to Type K or Type J
- t-CF**..... Select the Temp. unit to °C or °F
- SP-t**.....Set sampling time ( Second )
- Sd F**..... SD memory card Format

**Remark :**

***During execute the " Advanced Setting " function, if press " Esc Button " ( 3-2, Fig. 1 ) once will exit the " Advanced Setting " function, the LCD will return to normal screen.***

### ***7-1 Set clock time ( Year/Month/Date, Hour/Minute/ Second )***

When the lower display show " dAtE "

- 1) Press the " Enter Button " ( 3-4, Fig. 1 ) once, Use the " ▲ Button " ( 3-6, Fig. 1 ) or " ▼ Button " ( 3-5, Fig. 1 ) to adjust the value ( Setting start from Year value ). After the desired value is set, press the " Enter Button " ( 3-4, Fig. 1 ) once will going to next value adjustment ( for example, first setting value is Year then next to adjust Month, Date, Hour, Minute, Second value ).
- 2) After set all the time value ( Year, Month, Date, Hour, Minute, Second ), the screen will jump to " SD card Decimal character " setting screen ( Chapter 7-2 ).

**Remark :**

***After the time value is setting, the internal clock will run precisely even Power off if the battery is under normal condition ( No low battery power ).***

### ***7-2 Decimal point of SD card setting***

The numerical data structure of SD card is default used the " ." as the decimal, for example "20.6" "1000.53" . But in certain countries ( Europe ...) is used the " ," as the decimal point, for example " 20,6 " "1000,53". Under such situation, it should change the Decimal character at first.

When the lower display show " dEC "

- 1) Use the " ▲ Button " ( 3-6, Fig. 1 ) or " ▼ Button " ( 3-5, Fig. 1 ) to select the upper value to " bASIC " or " Euro " .

**bASIC - Use " ." as the Decimal point with default.**  
**Euro - Use " ," as the Decimal point with default.**

- 2) After select the upper text to " bASIC " or " Euro " , press the " Enter Button " ( 3-4, Fig. 1 ) will save the setting function with default.

### ***7-3 Auto power OFF management***

When the lower display show " PoFF "

- 1) Use the " ▲ Button " ( 3-6, Fig. 1 ) or " ▼ Button " ( 3-5, Fig. 1 ) to select the upper value to " yES " or " no " .

**yES - Auto Power Off management will enable.**  
**no - Auto Power Off management will disable.**

- 2) After select the upper text to " yES " or " no " , press the " Enter Button " ( 3-4, Fig. 1 ) will save the setting function with default.

#### ***7-4 Set beeper sound ON/OFF***

When the lower display show " bEEP "

- 1) Use the " ▲ Button " ( 3-6, Fig. 1 ) or " ▼ Button " ( 3-5, Fig. 1 ) to select the upper value to " yES " or " no ".

**yES - Meter's beep sound will be ON with default.**  
**no - Meter's beep sound will be OFF with default.**  
**is power ON.**

- 2) After select the upper text to " yES " or " no ", press the " Enter Button " ( 3-4, Fig. 1 ) will save the setting function with default.

#### ***7-5 Select the Thermometer to Type K or Type J***

When the lower display show " tYPE "

- 1) Use the " ▲ Button " ( 3-6, Fig. 1 ) or " ▼ Button " ( 3-5, Fig. 1 ) to select the Display unit to " K " or " J ".

**K - Type K thermometer**  
**j - Type J thermometer**

- 2) After Display unit is selected to " K " or " J ", press the " Enter Button " ( 3-4, Fig. 1 ) will save the setting function with default.

### ***7-6 Select the Temp. unit to °C or °F***

When the lower display show " t-CF "

- 1) Use the " ▲ Button " ( 3-6, Fig. 1 ) or " ▼ Button " ( 3-5, Fig. 1 ) to select the upper Display text to " C " or " F ".

**C - Temperature unit is °C**

**F - Temperature unit is °F**

- 2) After Display unit is selected to " C " or " F ", press the " Enter Button " ( 3-4, Fig. 1 ) will save the setting function with default.

### ***7-7 Set sampling time ( Seconds )***

When the lower display show " SP-t "

- 1) Use the " ▲ Button " ( 3-6, Fig. 1 ) or " ▼ Button " ( 3-5, Fig. 1 ) to adjust the value ( 0, 1, 2, 5, 10, 30, 60, 120, 300, 600, 1800, 3600 seconds ).
- 2) After the Sampling value is selected, press the " Enter Button " ( 3-4, Fig. 1 ) will save the setting function with default.

### ***7-8 SD memory card Format***

When the lower display show " Sd F "

- 1) Use the " ▲ Button " ( 3-6, Fig. 1 ) or " ▼ Button " ( 3-5, Fig. 1 ) to select the upper value to " yES " or " no ".

**yES - Intend to format the SD memory card**

**no - Not execute the SD memory card format**

- 2) If select the upper to " yES ", press the " Enter Button " ( 3-4, Fig. 1 ) once again, the Display will show text " yES Enter " to confirm again, if make sure to do the SD memory card format, then press " Enter Button " once will format the SD memory clear all the existing data that already saving into the SD card.

## 8. POWER SUPPLY from DC ADAPTER

The meter also can supply the power supply from the DC 9V Power Adapter ( optional ). Insert the plug of Power Adapter into " DC 9V Power Adapter Input Socket " ( 3-12, Fig. 1 ). The meter will permanent power ON when use the DC ADAPTER power supply ( The power Button function is disable ).

## 9. BATTERY REPLACEMENT

- 1) When the left corner of LCD display show " , it is necessary to replace the battery. However, in-spec. measurement may still be made for several hours after low battery indicator appears before the instrument become inaccurate.
- 2) Loose the screws of the " Battery Cover " ( 3-13, Fig. 1 ) and take away the " Battery Cover " from the instrument and remove the battery.
- 3) Replace with DC 1.5 V battery ( UM3, AA, Alkaline/heavy duty ) x 6 PCs, and reinstate the cover.
- 4) Make sure the battery cover is secured after changing the battery.

## 10. SYSTEM RESET

If the meter happen the troubles such as :

*CPU system is hold ( for example, the key button can not be operated... ).*

Then make the system RESET will fix the problem.  
The system RESET procedures will be either following method :

During the power on, use a pin to press the " Reset Button " ( 3-11, Fig. 1 ) once a while will reset the circuit system.

## 11. RS232 PC SERIAL INTERFACE

The instrument has RS232 PC serial interface via a 3.5 mm terminal ( 3-10, Fig. 1 ).

The data output is a 16 digit stream which can be utilized for user's specific application.

A RS232 lead with the following connection will be required to link the instrument with the PC serial port.



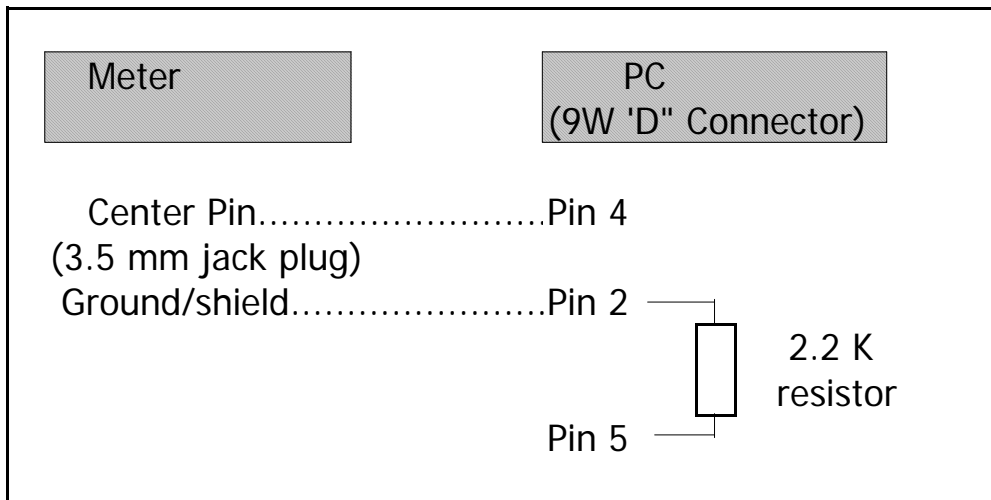

The 16 digits data stream will be displayed in the following format :

D15 D14 D13 D12 D11 D10 D9 D8 D7 D6 D5 D4 D3 D2 D1 D0

**Each digit indicates the following status :**

D15	Start Word
D14	4
D13	When send the upper display data = 1 When send the lower display data = 2
D12, D11	Annunciator for Display °C = 01      °F = 02 mW/cm <sup>2</sup> = A8 ( D12 = A, D11 = 8 )
D10	Polarity 0 = Positive    1 = Negative
D9	Decimal Point(DP), position from right to the left, 0 = No DP, 1= 1 DP, 2 = 2 DP, 3 = 3 DP
D8 to D1	Display reading, D1 = LSD, D8 = MSD For example : If the display reading is 1234, then D8 to D1 is : 00001234
D0	End Word

RS232 FORMAT : 9600, N, 8, 1

Baud rate	9600
Parity	No parity
Data bit no.	8 Data bits
Stop bit	1 Stop bit

## 12. Optional Type K Temp. probe

(Type K) TP-01	<ul style="list-style-type: none"> <li>* Max. short-tern operating Temperature: 300 °C (572 °F).</li> <li>* It is an ultra fast response naked-bead thermocouple suitable for many general purpose application.</li> </ul>
Thermocouple Probe (Type K), TP-02A	<ul style="list-style-type: none"> <li>* Measure Range: -50 °C to 900 °C, -58 °F to 1650 °F.</li> <li>* Dimension: 12cm tube, 3.2mm Dia.</li> </ul>
Thermocouple Probe (Type K), TP-03	<ul style="list-style-type: none"> <li>* Measure Range: -50 °C to 1100 °C, -58 °F to 2012 °F.</li> <li>* Dimension: 13.6cm tube, 8mm Dia.</li> </ul>
Surface Probe (Type K), TP-04	<ul style="list-style-type: none"> <li>* Measure Range: -50 °C to 400 °C, -58 °F to 752 °F.</li> <li>* Size : Temp. sensing head - 15 mm Dia. Probe length - 120 mm.</li> </ul>

## 13. PATENT

The meter ( SD card structure ) already get patent or patent pending in following countries :

Germany	Nr. 20 2008 016 337.4
JAPAN	3151214
CHINA	ZL 2008 2 0189918.5 ZL 2008 2 0189917.0