



Laboratory Equipment Manufacturer
www.mrclab.com



RF and LF measurement

RF Strength, LF Magnetic Fields/Electric Fields Meter

Multi-Field EMF Meter

Model : EMF-840



Your purchase of this Personal Multi-Field EMF Meter Strength Meter marks a step forward for you into the field of precision measurement. Although this METER is a complex and delicate instrument, its durable structure will allow many years of use if proper operating techniques are developed. Please read the following instructions carefully and always keep this manual within easy reach.

OPERATION MANUAL

PLEASE READ THIS MANUAL CAREFULLY BEFORE OPERATION

3, Hagavish st. Israel 58817 Tel: 972 3 5595252, Fax: 972 3 5594529

mrc@mrclab.com

MRC. 3.20

TABLE OF CONTENTS

1. FEATURES.....	1
2. SPECIFICATIONS.....	2
3. FRONT PANEL DESCRIPTION.....	4
4. MEASURING PROCEDURE.....	5
4-1 Measurement LFMagnetic Fields/Electric Field, RF EMF Strength	5
4-2 Data Hold.....	7
4-3 Data Record (Max., Min. reading).....	7
4-4 LCD brightness select.....	7
4-5 Sound Alert Table	7
5. ADVANCED SETTING.....	8
5-1 Auto power OFF management.....	8
5-2 Set beeper sound ON/OFF	9
5-3 Set LF UNIT	9
5-4 Set EMF UNIT.....	10
6. POWER SUPPLY	11
7. BATTERY REPLACEMENT.....	11

1. FEATURES

- * RF application :
For electromagnetic field strength measurement including mobile phone base station antenna radiation, RF power measurement for transmitters, wireless LAN (Wi-Fi) detection/ installation, wireless communication applications (CW, TDMA, GSM, DECT) and microwave leakage.
- * RF power measurement Range/Resolution :
Frequency range : 50 MHz to 3.5 GHz.
30.00 mV/m to 11.00 V/m, 0.001,0.01, 0.1 mV/m,V/m.
0.02 μ W/cm² to 32.09 μ W/cm², 0.01 μ W/cm².
0.02 μ W/m² ~ 320.9 mW/m², 0.001,0.01 , 0.1 μ W/m²,mW/m²
0.02 mA/m to 29.17 mA/m, 0.01 mA/m.
- * LF application :
The EMF tester (LF) is designed to provide user a quick reliable and easy way to measure
electromagnetic field radiation levels around power line , home appliances and industrial devices.
- * Magnetic Fields Measurement range/Resolution:
Frequency range : 50 Hz to 60 Hz.
mG : 200.0 to 2000, 0.1 mG, 1 mG.
 μ T: 20.00 to 200.0, 0.01 μ T, 0.1 μ T.
- * Electric Fields Measurement range/Resolution :
Frequency range : 50 Hz to 60 Hz.
50 V/m to 2000 V/m, 1 V/m.
- * 2.4" TFT LCD display to easy reading.
Light weight and small size case design are suitable for handling with one hand.
- * Wristlet design provides extra protection to the instrument especially for user one hand operation.
- * Built- in microprocessor circuit assures excellent performance and accuracy.
- * Concise and compact buttons arrangement, easy operation.
- * Memorize the maximum and minimum value with recall.
- * Hold function to freeze the current reading value
- * Power Supply DC 1.5V, UM4-AAA battery x 3 PCs.

2. SPECIFICATIONS

2-1 General Specifications

Display	LCD view size : 2.4" TFT LCD.
Measurement	EMF (Electromagnetic field tester.)
Band width	RF:50~3.5 MHz, LF: 50/60 Hz
Number Axes	Single Axis.
Operating Humidity	Max. 80% RH.
Operating Temperature	0 to 50 °C (32 to 122 °F)
Over Input Display	Indication of "- - - - "
Data Hold	Freeze the display reading.
Memory Recall	Maximum & Minimum value.
Sampling Time of Display	Approx. 1 second.
Power Supply	DC 1.5V ,UM4-AAA battery X 3 PCs (DC 4.5 V battery)
Power Consumption	Approx. DC 26 mA ~ 49 mA (0-3rd-order LCD Backlight brightness)
Power off	Auto shut off saves battery life or manual off by push button.
Weight	160g (battery included)
Dimension	HWD 107 x 45 x 20 mm (4.2 x 1.8 x 1.2 inch).
Standard Accessory	Instruction Manual..... 1 pc
Optional Accessories	Soft carrying case, CA-05A.

2-2 Electrical Specifications (23±5 °C , 25% ~ 75 % RH)

RF EMF tester METER

Unit	Range	Resolution	Absolute error
mV/m,V/m	30.00mV/m ~ 11.00 V/m	0.001,0.01 , 0.1	1.0dB @ at 1 V/m & 900 MHz
μW/cm2	0.02 ~ 32.09 μW/cm2	0.01 , 0.1	
μW/m2,mW/m2	0.02 μW/m2 ~ 320.9 mW/m2	0.001,0.01 , 0.1	
mA/m	0.02 ~ 29.17 mA/m	0.01 , 0.1	

LF - Magnetic Fields tester METER

Unit	Range	Resolution	Accuracy
μT (micro Tesla)	20.00 ~ 200.0 μT	0.01 μt , 0.1 μT	±12% rdg +5 dgt @ at 50 Hz or 60 Hz
mG (milli Gauss)	200.0 ~ 2000 mG	0.1 mG , 1 mG	

LF- Electric Field tester METER

Unit	Range	Resolution	Accuracy
V/m	50 V/m ~ 2000 V/m	1 V/m	±7% rdg + 20 dgt @ at 50 Hz or 60 Hz

@ Above specification tests under the environment RF Field Strength less than 3 V/M & frequency less than 30 MHz only.

3. FRONT PANEL DESCRIPTION

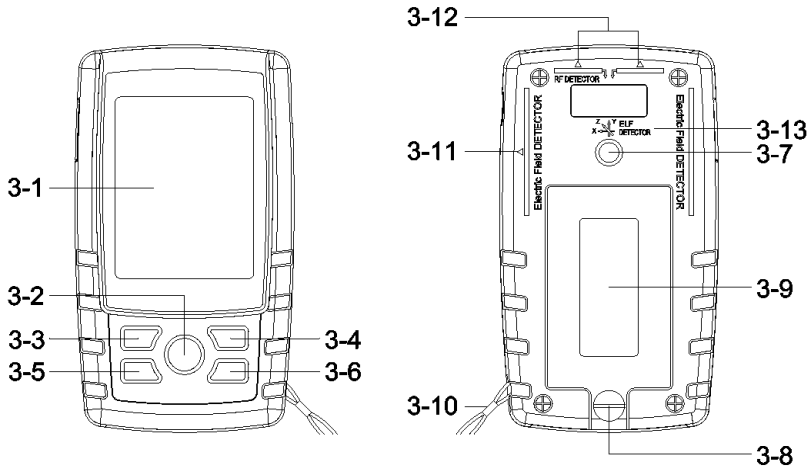

Fig. 1

- 3-1 Display.
- 3-2 Power Button
- 3-3 Hold Button
- 3-4 REC (Enter) Button
- 3-5 ▲ Button (SET Button)
- 3-6 ▼ Button
- 3-7 Tripod Fix Nut
- 3-8 Battery Cover Screws (Logger Button)
- 3-9 Battery compartment/Cover
- 3-10 Wristlet
- 3-11 Electric Field detector
- 3-12 RF detector
- 3-13 LF detector

4. MEASURING PROCEDURE

4-1 MEASUREMENT

- 1) Turn on the meter by pressing the " Power Button "
(3-2, Fig. 1) > 1.5 seconds continuously.

* *Pressing the " Power Button " (3-2, Fig. 1)
continuously and > 1.5 seconds again will turn off the
meter.*

- 2) measurement UNIT select .

LF Unit select please refrence 5-3 (Page 9)

EMF Unit select please refrence 5-4 (Page 10)

LF-Electric Field Measuremen value

The Meter measures the electric field (Electrical Power)
in the atmosphere of the sensor's surroundings

Remark:

- * Hold the meter at arm's length.
- * The sensor measur orientation please refrence meter case back.
- * According the indicated direction of the electric field sensor
to Perform test, refrence figure 2.

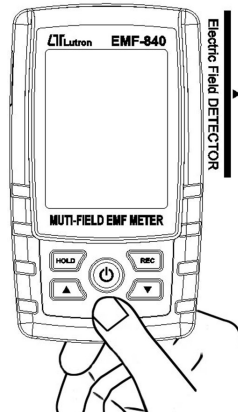

figure 2.

LF - Magnetic Field Measuremen value (Magnetic field)

Point the front section of the meter to ward the desired electromagnetic
field to take a measurement.

The meter can simultaneously displays the electromagnetic field readings
of individual (X,Y,Z) and the aggregated Magnetic field readings.

remark:

* If the meter is moved quickly, may be field strength values will be displayed which do not reflect the actual field conditions.

Measurement Note:

- * Hold the meter at arm's length.
- * during the measurement please keep the meter steady .
- * If the test field conditions are unknown, please Make several measurements at various locations in the work place or other areas of interest , this is particularly important.

RF strength meter Measuremen value

Point the front face of the meter toward the desired RF field to take a measurement.

remark:

* If the meter is moved quickly, may be field strength values will be displayed which do not reflect the actual field conditions.

Measurement Note:

- * Hold the meter at arm's length.
- * The meter sensing area, Point toward signal source, reference figure 3.
- * during the measurement please keep the meter steady .
- * If the test field conditions are unknown, please Make several measurements at various locations in the work place or other areas of interest , this is particularly important.

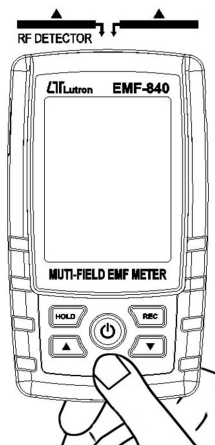

figure 3.

4-2 Data Hold

During the measurement, press the " Hold Button " (3-3, Fig. 1) once will hold the measured value & the " HOLD Symbol " indicator will be light, Press the " Hold Button " once again will release the data hold function , (3-3, Fig. 1) red led indicator will be quenched

4-3 Data Record (Max., Min. reading)

- 1) The data record function records the maximum and minimum readings. Press the " REC Button " (3-4, Fig.1) once to start the Data Record function and there will be a " REC "Symbol indicator " will be light.
- 2) With the " REC " Symbol is light on the display :
 - a) Press the " REC Button " (3-4, Fig. 1) once, the " REC and MAX Symbol indicator will be light , and the maximum value will appear on the display.
 - b) Press the " REC Button " (3-4, Fig. 1) again, the " REC and MIN "Symbol indicator will be light , and the minimum value will appear on the display.
 - c) To exit the memory record function, just press the " REC " button for 1.5 seconds at least. The display will revert to the current reading, red led indicator will be quenched

4-4 LCD brightness select

Depending on the brightness of the environment, can use the "Backlight Button " (3-2, Fig. 1) select from 3rd-order LCD Backlight brightness.

4-5 Sound Alert Table

	Magnetic Fields	Electrical Fields	RF Strength	lcdbar color indicator
Low	≤ 10	≤ 500 V/m	≤ 0.9 mW/m ²	green
Medium	>10 mG	>500 V/m	>1 mW/m ²	yellow
High	>100 mG	>1000 V/m	>10 mW/m ²	red

Note:

- * Alarm beeper sounds when readings enter the red region
- * Alert Table for reference

5. ADVANCED SETTING

Under do not execute the Datalogger function, press the " SET Button " (3-5, Fig. 1) continuously at least 1.5 seconds will enter the " Advanced Setting " mode. then press the " SET Button " (3-5, Fig. 1) once a while display will show :

POFF..... Auto power OFF management

BEEP..... Set beeper sound ON/OFF

LF UNIT... Set LF unit .

EMF UNIT..... Set EMF unit .

Remark :

During execute the " Advanced Setting " function,if press " Power Button " (3-2, Fig. 1) once will exit the " Advanced Setting " function, the lcd display will return to normal screen.

5-1 Auto power OFF management

When the " AUTO POWER OFF " text is mark (white color)

1) Press "Enter(REC button)" into the setting function,then use the " ▲ Button " (3-5, Fig. 1) or " ▼ Button " (3-6, Fig. 1) to select the upper value to " Yes " or " No " .

Yes - Auto Power Off management will enable.

No - Auto Power Off management will disable.

2) After select the upper text to " Yes " or " No " , press the " Enter(REC Button) " (3-4, Fig. 1) will save the setting function with default and Return to the previous leve.

3) After press the " Power Button " (3-2, Fig. 1) will back to nomal measurement

5-2 Set beeper sound ON/OFF

When the " BEEPER SOUND " text is mark (white color)

- 1) Press "Enter(REC button)" into the setting function, then use the " ▲ Button " (3-5, Fig. 1) or " ▼ Button " (3-6, Fig. 1) to select the upper value to " Yes " or " No ".

Yes- Meter's beep sound will be ON with default.

No - Meter's beep sound will be OFF with default.

- 2) After select the upper text to " Yes " or " No ", press the " Enter(REC button) " (3-4, Fig. 1) will save the setting function with default and Return to the previous level.
- 3) After press the " Power Button " (3-2, Fig. 1) will back to normal measurement

5-3 Set LF UNIT

When the " LF UNIT " text is mark (white color)

- 1) Press "Enter(REC button)" into the setting function, then use the " ▲ Button " (3-5, Fig. 1) or " ▼ Button " (3-6, Fig. 1) to select the LF unit to " uT " or " mG ".

uT- micro Tesla

mG - milli Gauss

- 2) After select the LF unit to " uT " or " mG ", press the " Enter(REC button) " (3-4, Fig. 1) will save the setting function with default and Return to the previous level.
- 3) After press the " Power Button " (3-2, Fig. 1) will back to normal measurement

5-4 Set EMF UNIT

When the " EMF UNIT " text is mark (white color)

- 1) Press "Enter(REC button)" into the setting function, then use the " ▲ Button " (3-5, Fig. 1) or " ▼ Button " (3-6, Fig. 1) to select the EMF unit to " $\text{mW/m}^2 - \mu\text{W/m}^2$ " or " $\mu\text{W/m}^2$ " or " $\text{V/m} - \text{mV/m}$ " or " mA/m " .
- 2) After select the LF unit to " $\text{mW/m}^2 - \mu\text{W/m}^2$ " or " $\mu\text{W/m}^2$ " or " $\text{V/m} - \text{mV/m}$ " or " mA/m " , press the " Enter(REC button) " (3-4, Fig. 1) will save the setting function with default and Return to the previous level.
- 3) After press the " Power Button " (3-2, Fig. 1) will back to normal measurement

6. POWER SUPPLY

The meter power supply is DC 1.5 V battery UM4, AAA x 3 pcs

7. BATTERY REPLACEMENT

- 1) When the left corner of  "Low battery" indicator is light, it is necessary to replace the battery. However, in-spec. measurement may still be made for several hours after low battery indicator appears before the instrument become inaccurate.
- 2) Loosen the "Battery Cover Screws" (3- 8, Fig. 1) and take away the " Battery Cover " (3- 9, Fig. 1) from the instrument and remove the battery.
- 3) Replace with DC 1.5 V battery (UM4, AAA, Alkaline/heavy duty) x 3 PCs, and reinstate the cover.
- 4) Make sure the battery cover is secured after changing the battery.