

# PRECISION BALANCES PS 3Y



release date 10-03-2017



PS 200/2000.3Y - PS 1000.3Y

PS 1500.3Y - PS 6000.3Y

PS 6100.3Y - PS 10100.3Y

Balances PS 3Y series are laboratory weighing instruments featuring 5,7" LCD colour touch panel which provides new possibilities of balance operation and presenting measurement results.

Personalization of balance settings is carried out in extended user profiles. 3Y series comes standard with system of automatic internal adjustment.

Level control is based on LevelSENSING system, RADWAG patented solution, which uses a system of an electronic level. New function of PS 3Y series is online monitoring of ambient conditions through built-in sensors or an external ambient conditions module THB 3 series.

PS 3Y series offers two models of weighing pans which enable weighing with different accuracy. New working mode of the PS 3Y series: differential weighing, allows the balance to control mass of the same sample subjected to differed processes over time. Extended databases enable storing all carried out measurements, with option of printing and exporting them. Standard and user defined printouts allow for maintaining documentation complying with GLP/GMP requirements practically in any application. PS 3Y series features an independent mass control mode carried out with application of an automatic feeder PA-02/H.

3Y series balances are equipped with **802.11b/g/n Wireless module** communication interface operating with frequency range 2.4 ÷ 2.472 GHz (1÷13 channels). Communication is established likewise as for any other interfaces, e.g.: RS 232, Ethernet.

### NOVELTY:

**The new PS.3Y high capacity balances** (6100, 8100 and 10100) feature centrally fixed weighing pan and additional sealing ring. This solution improves air-tightness and simplifies cleaning.

To advance accuracy, the new balances have been equipped with metal anti-draft shield.

Additional assets are both expanded capacity (even up to 10.1 kg) and smaller dispersion of weighings – better repeatability.

- Parts counting
- Dosing
- Checkweighing
- Formulation
- Percent deviations
- Statistics
- Animal weighing
- Differential weighing
- Density determination
- Statistical Quality Control
- Autotest (GLP, Filter)
- GLP procedures
- Infrared sensors
- Ambient conditions monitoring
- Newton unit measurement
- Replaceable units
- Mass control
- Mass for titrator

## Technical specification:

	PS 200/2000.3Y M17	PS 250.3Y M17	PS 450.3Y M17	PS 600.3Y M17	PS 750.3Y M17	PS 1000.3Y M17	PS 1500.3Y M17	PS 2500.3Y M17	PS 4500.3Y M17	PS 6000.3Y M17
Max capacity	200/2000 g	250 g	450 g	600 g	750 g	1000 g	1500 g	2500 g	4500 g	6000 g
Minimal load	20 mg	20 mg	20 mg	20 mg	20 mg	20 mg	500 mg	500 mg	500 mg	500 mg
Readability	1/10 mg	1 mg	1 mg	1 mg	1 mg	1 mg	10 mg	10 mg	10 mg	10 mg
Tare range	-200/-2000 g	-250 g	-450 g	-600 g	-750 g	-1000 g	-1500 g	-2500 g	-4500 g	-6000 g
Linearity	±2/10 mg	±2 mg	±2 mg	±3 mg	±3 mg	±3 mg	±20 mg	±20 mg	±20 mg	±30 mg
Repeatability	1/10 mg	1 mg	1 mg	1,5 mg	1,5 mg	1,5 mg	10 mg	10 mg	10 mg	15 mg
Pan size	128×128 mm						195×195 mm			
Stabilization time	2 s / 1,5 s	2 s	2 s	2 s	2 s	2 s	1,5 s	1,5 s	1,5 s	1,5 s
Sensitivity drift	2 ppm/°C in temperature +15 ÷ +35 °C									
Minimum weight (USP)	1 g						10 g			
Minimum weight (U = 1%, k = 2)	0,1 g						1 g			
Working temperature	+10 ÷ +40 °C (*)									
Power supply	13,5 ÷ 16 V DC									
Interface	2×USB, 2×RS 232, 1×Ethernet, Wi-Fi 802.11 b/g/n, 4 inputs / 4 outputs (digital)									
Packaging size	716 × 360 × 260 mm									
Display	5,7" touch panel									

\* Balance maintains parameters in accordance with type approval in temperatures 15 ÷ 35°C;

## Technical specification:

	PS 6100.3Y	PS 8100.3Y	PS 10100.3Y
Max capacity	6100 g	8100 g	10100 g
Minimal load	500 mg	500 mg	500 mg
Readability	10 mg	10 mg	10 mg
Tare range	-6100 g	-8100 g	-10100 g
Linearity	±0,03 g	±0,03 g	±0,03 g
Repeatability	0,01 g	0,012 g	0,015 g
Pan size		195×195 mm	
Stabilization time	1,5 s	1,5 s	1,5 s
Sensitivity drift	2 ppm/°C in temperature +15 ÷ +35 °C		
Minimum weight (USP)	10 g		
Minimum weight (U = 1%, k = 2)	1 g		
Working temperature	+10 ÷ +40 °C (*)		
Power supply	13,5 ÷ 16 V DC		
Interface	2×USB, 2×RS 232, 1×Ethernet, Wireless Module, 4 inputs / 4 outputs (digital)		
Packaging size	716 × 360 × 260 mm		
Display	5,7" touch panel		
Net weight / gross weight	7,3 kg / 9,3 kg		

\* Balance maintains parameters in accordance with type approval in temperatures 15 ÷ 35°C

## Dimensions:

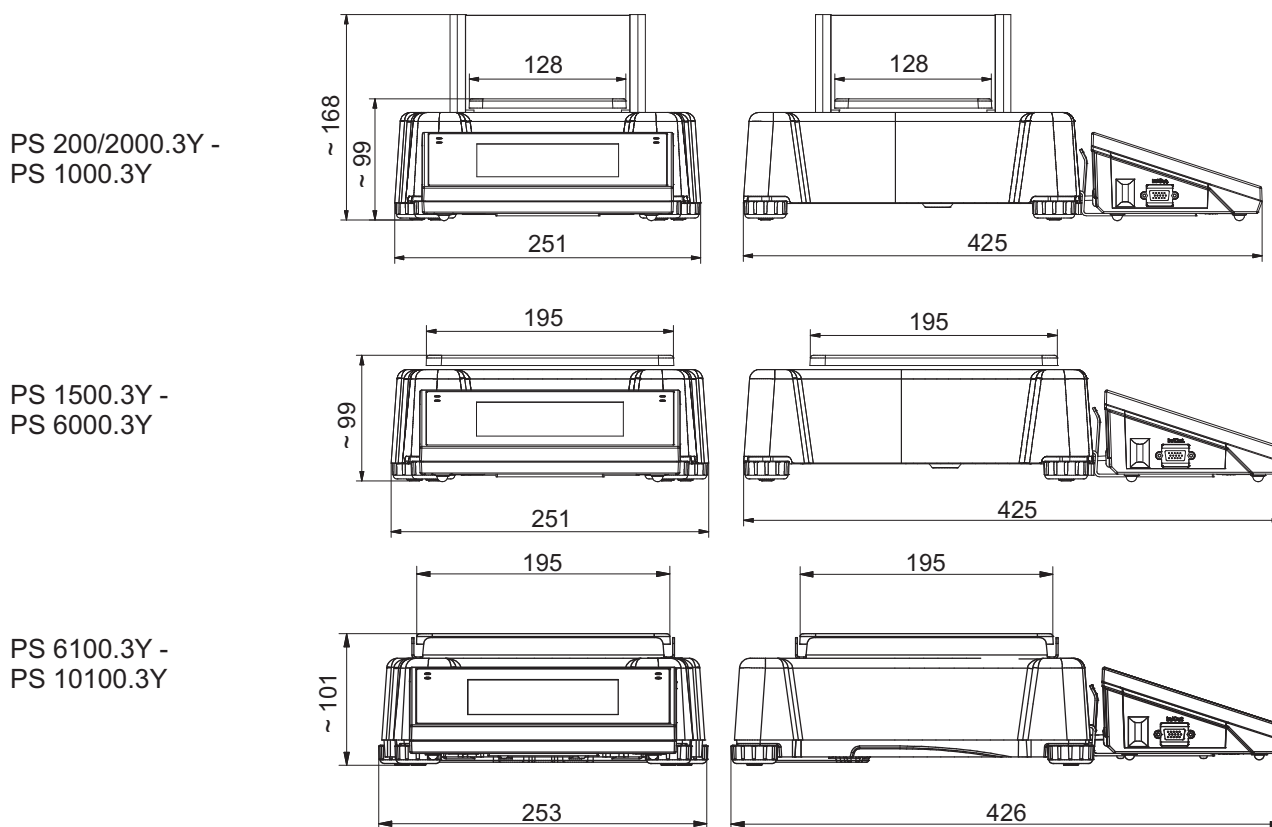

## Additional equipment:

Anti vibration table for laboratory balances	Automatic feeder PA-02/H
Printer Epson, Citizen	Mass standard
Foot button for tare or print functions	LCD display WD-5
Density determination kit for solids and liquids	Power adapter with battery and charger ZR-02
PC USB keyboard	Power loop output AP2-1 (plastic version)
Anti draft shield	Antistatic cable PA 1
Bar code scanner	Computer software: PW-WIN, RAD-KEY
THB 3 ambient conditions module	Cable: P0136, P0151